

REAL GOOD CHAIR

ASSEMBLY NOTES

WHEN GOOD JUST WON'T DO!

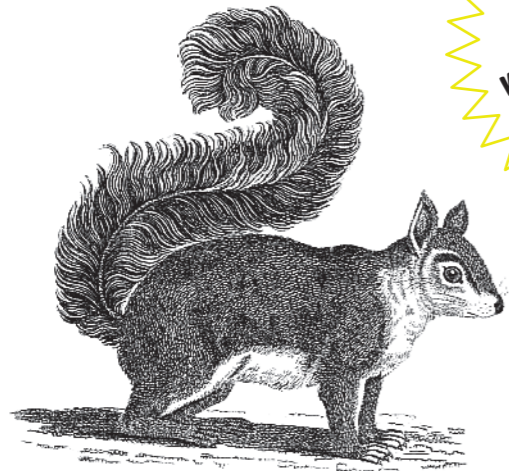

HARDWARE

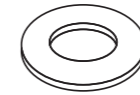

x4
3001



x4
8033

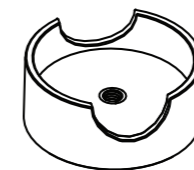

x4
8032



x4
2005

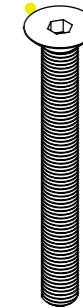

x4
1072

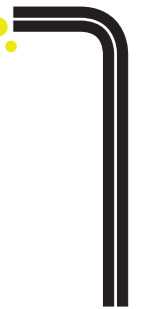

x1
9013

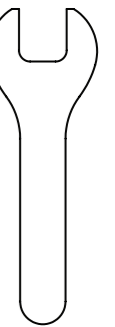

x1
9012

PARTS

x1

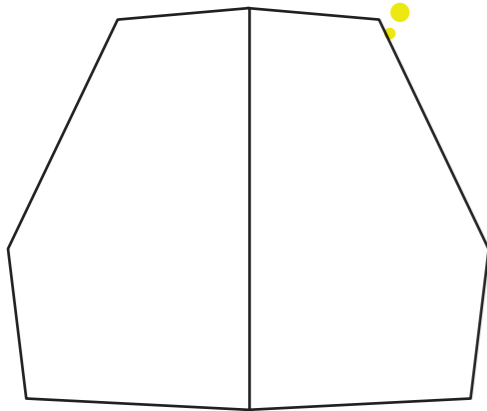

x1

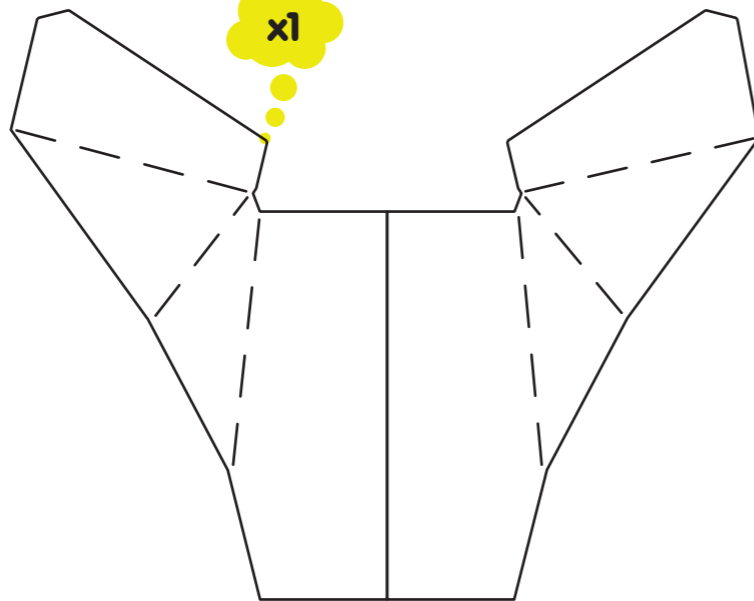

x1

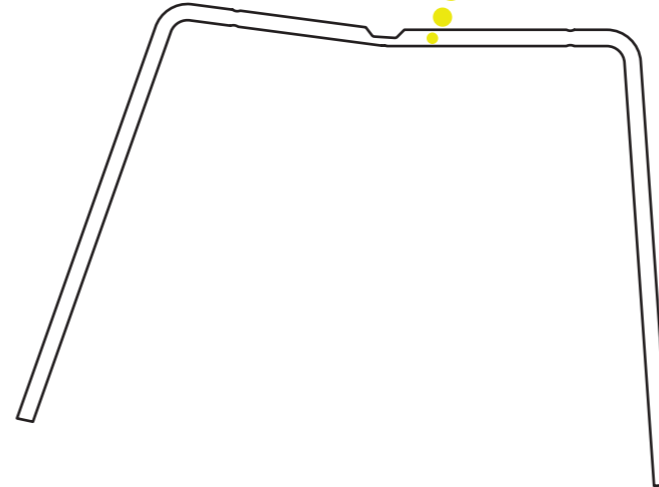

x1

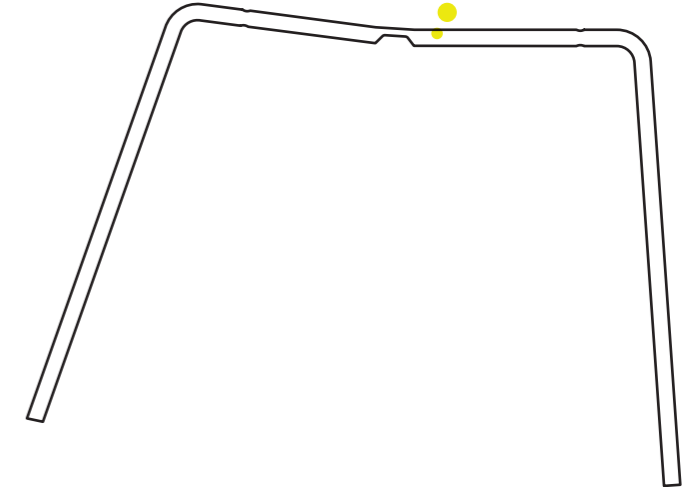

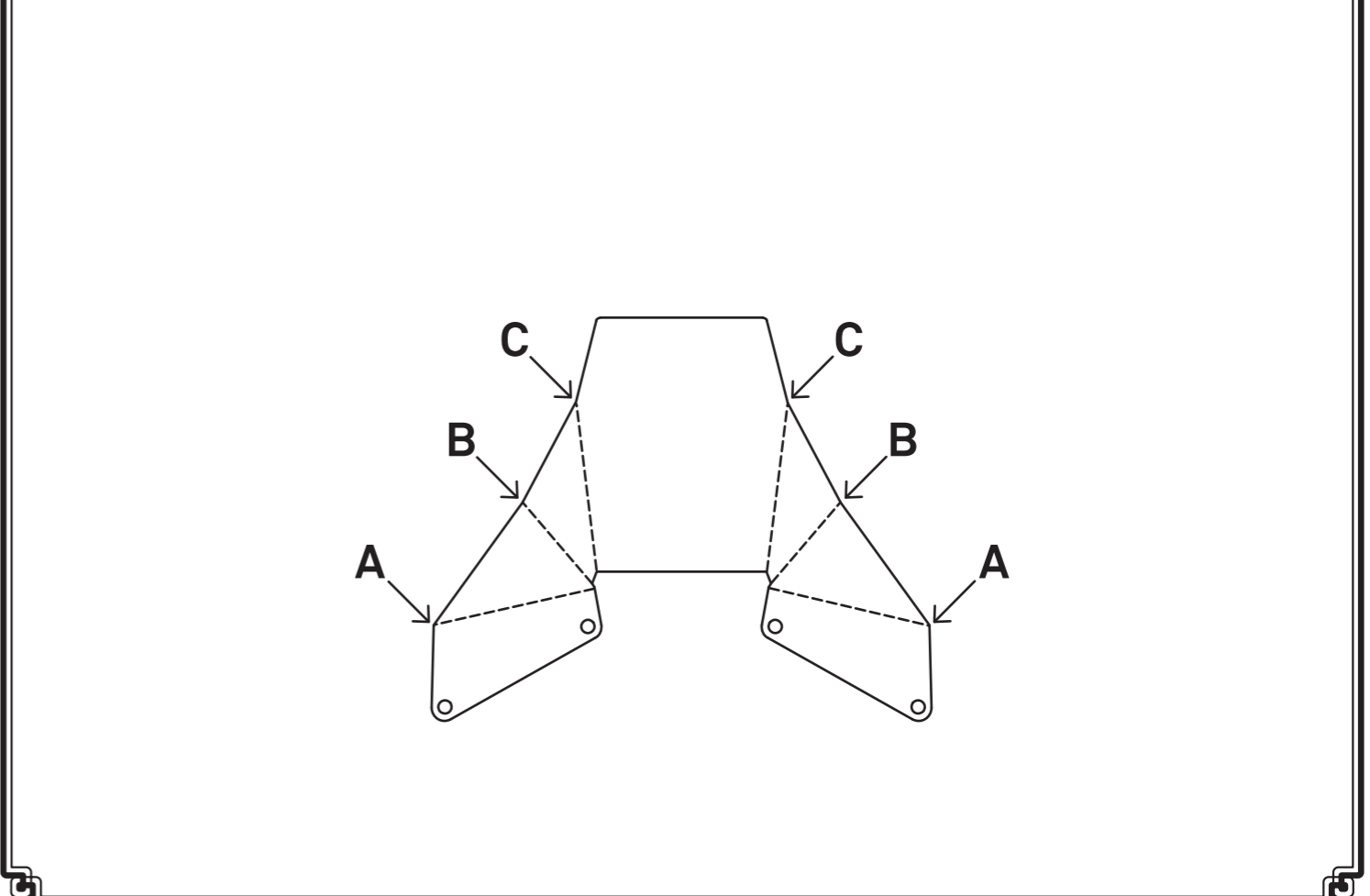
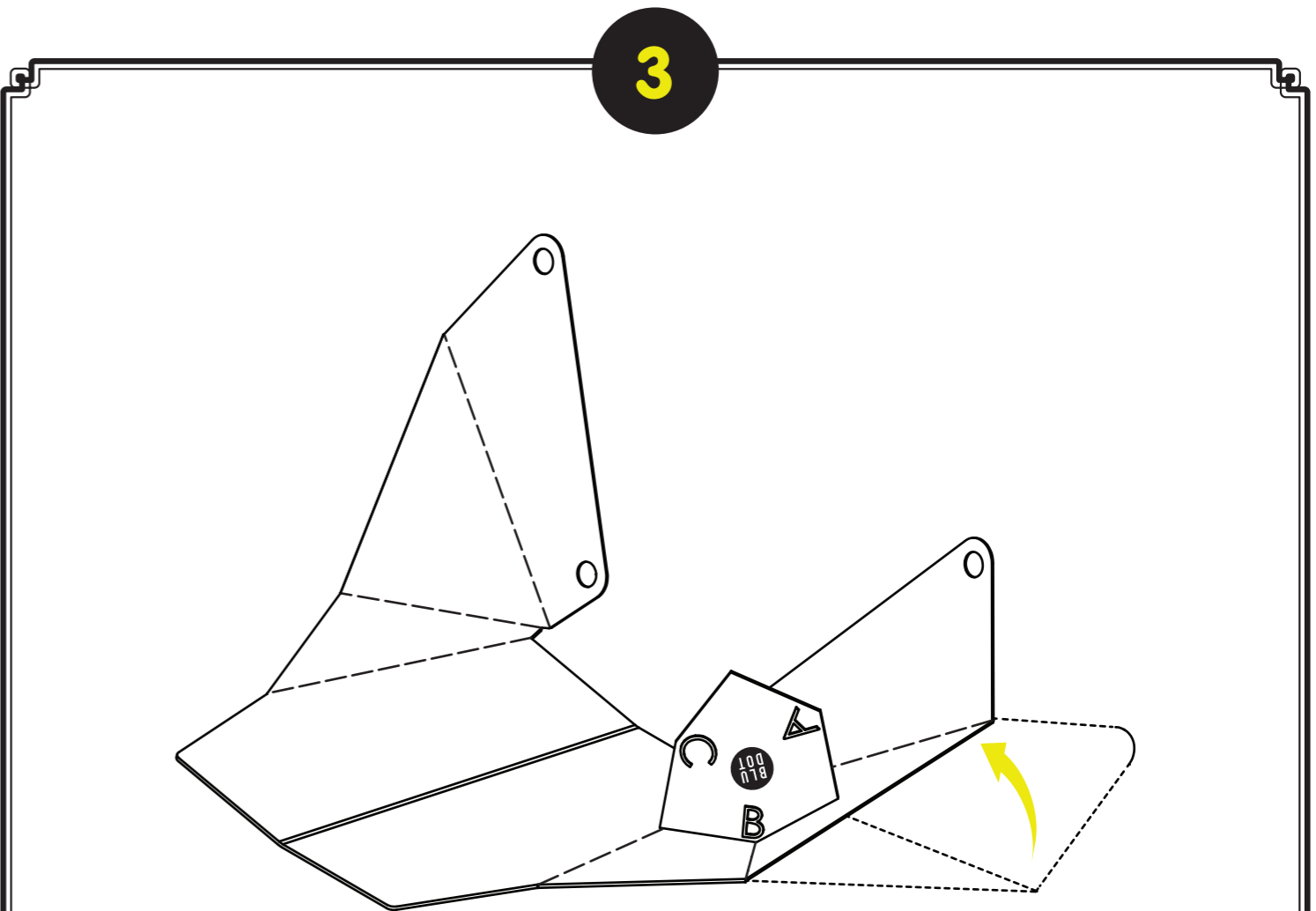
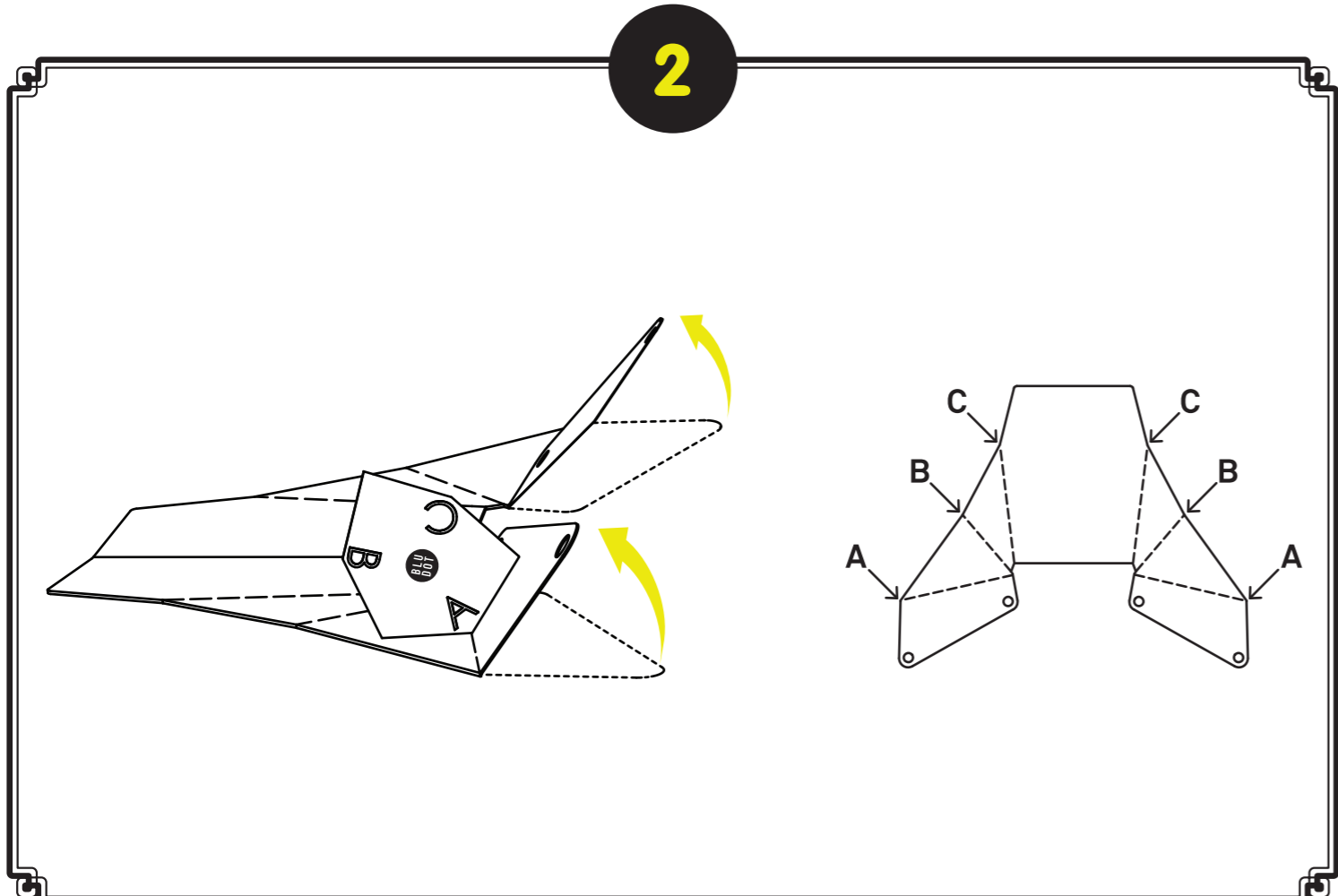
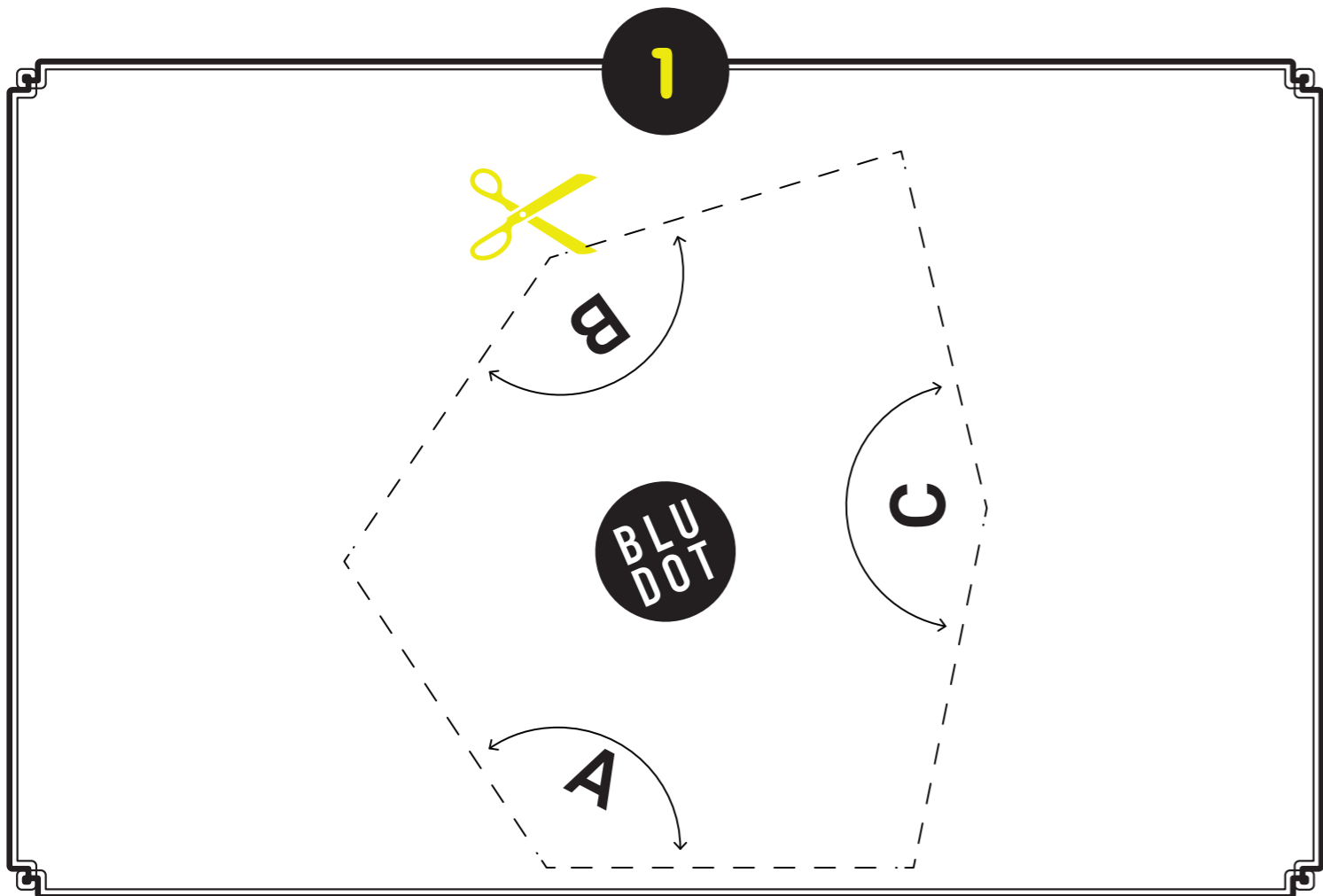

4

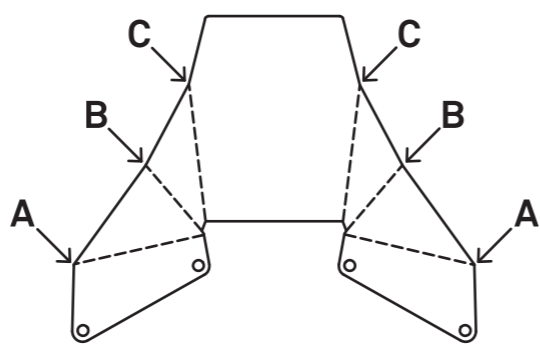
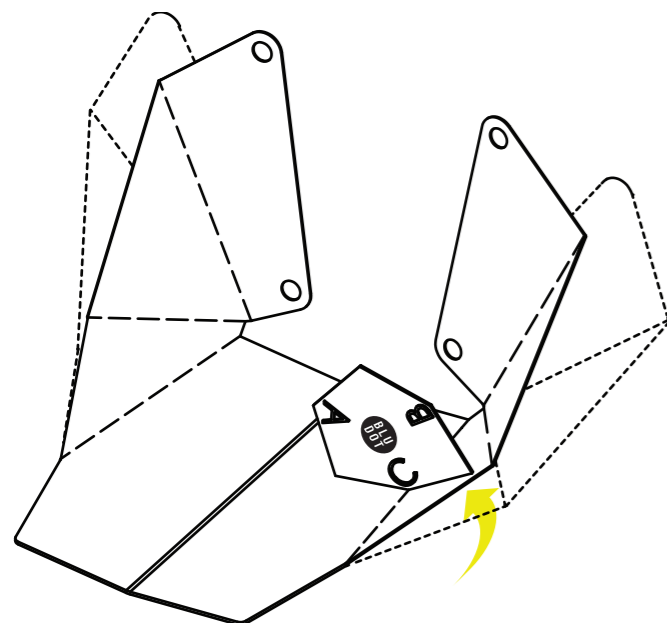

6

Rotate plastic sockets to receive leg assemblies.

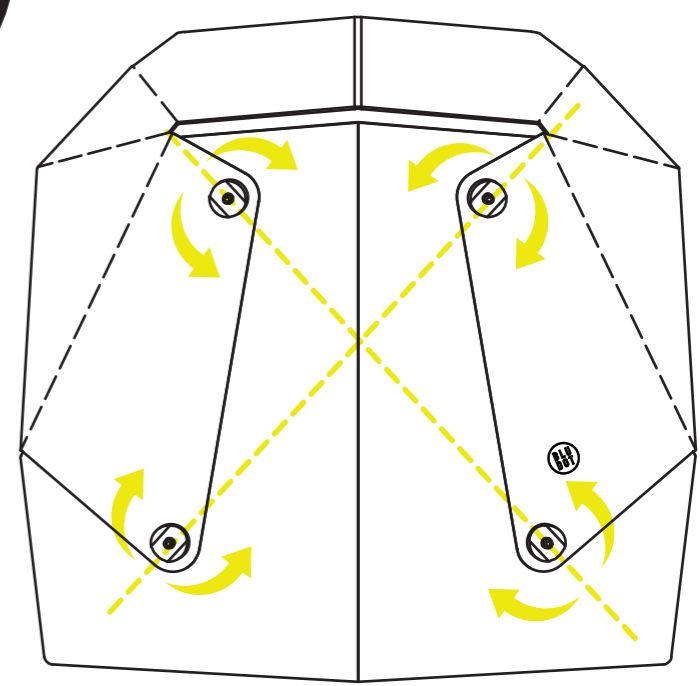

5

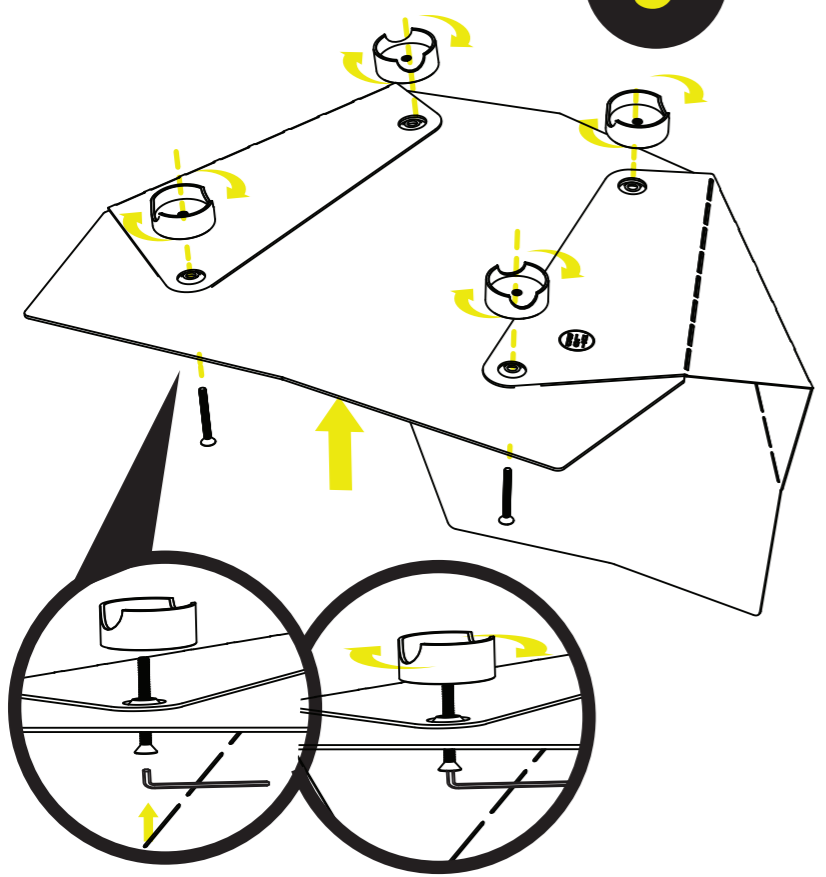

Fasten seat and back until flush but do not tighten fully.

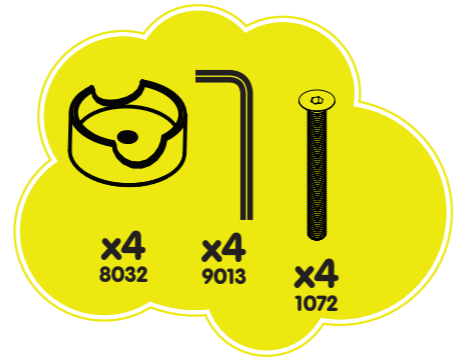

7a

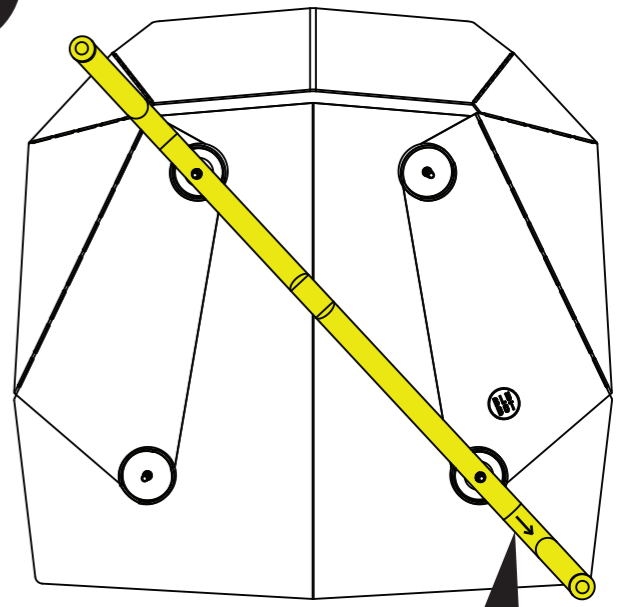
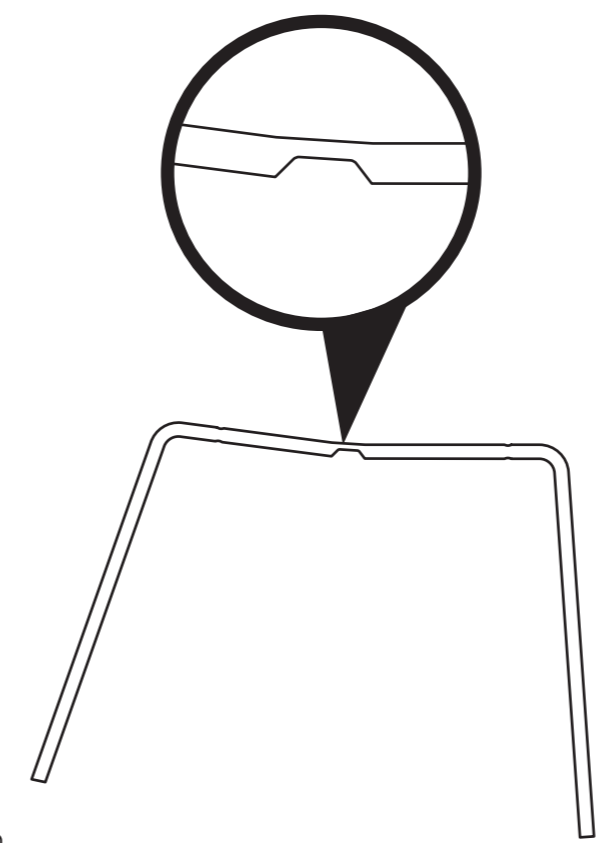

FRONT

7b

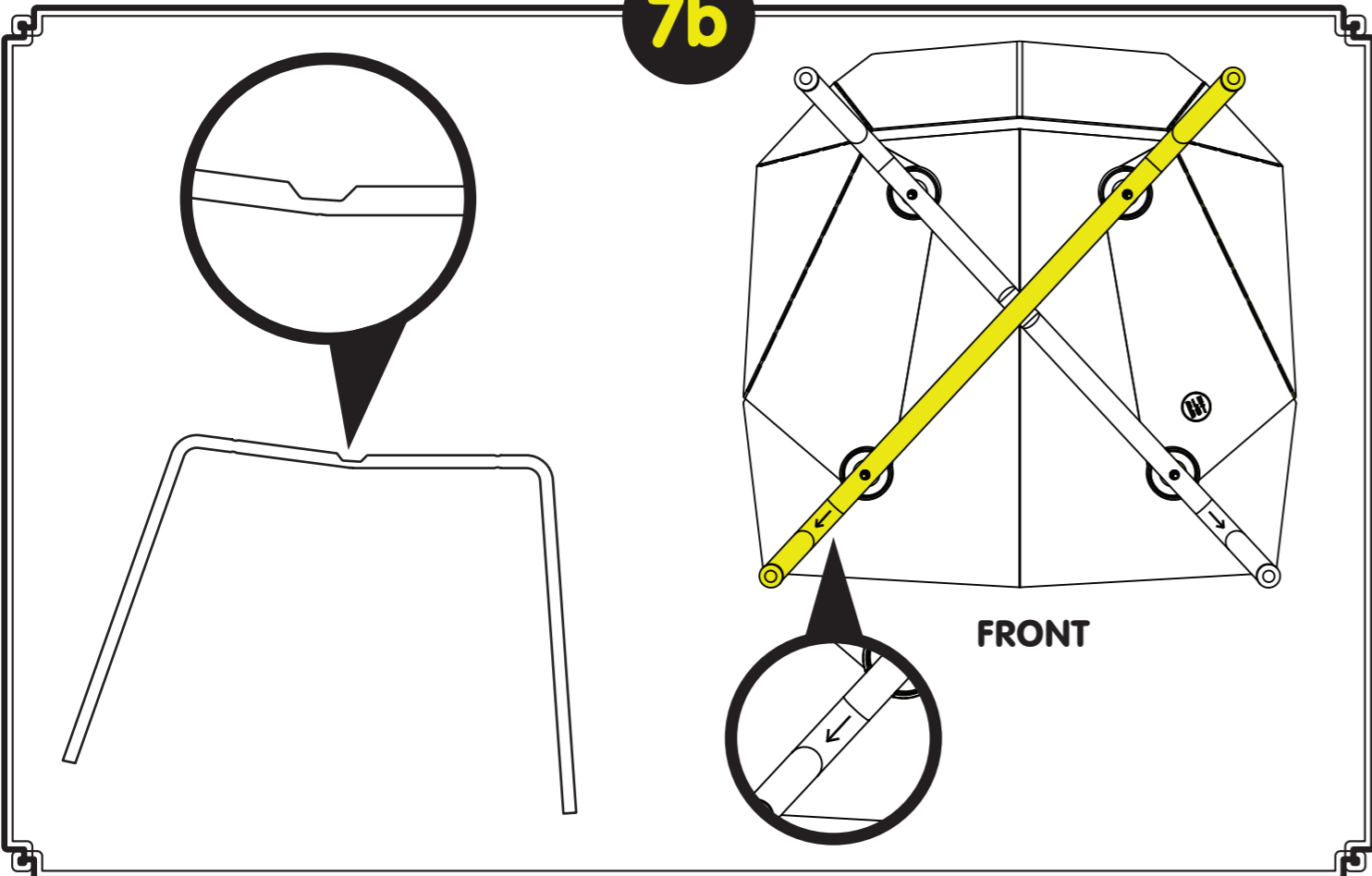

8

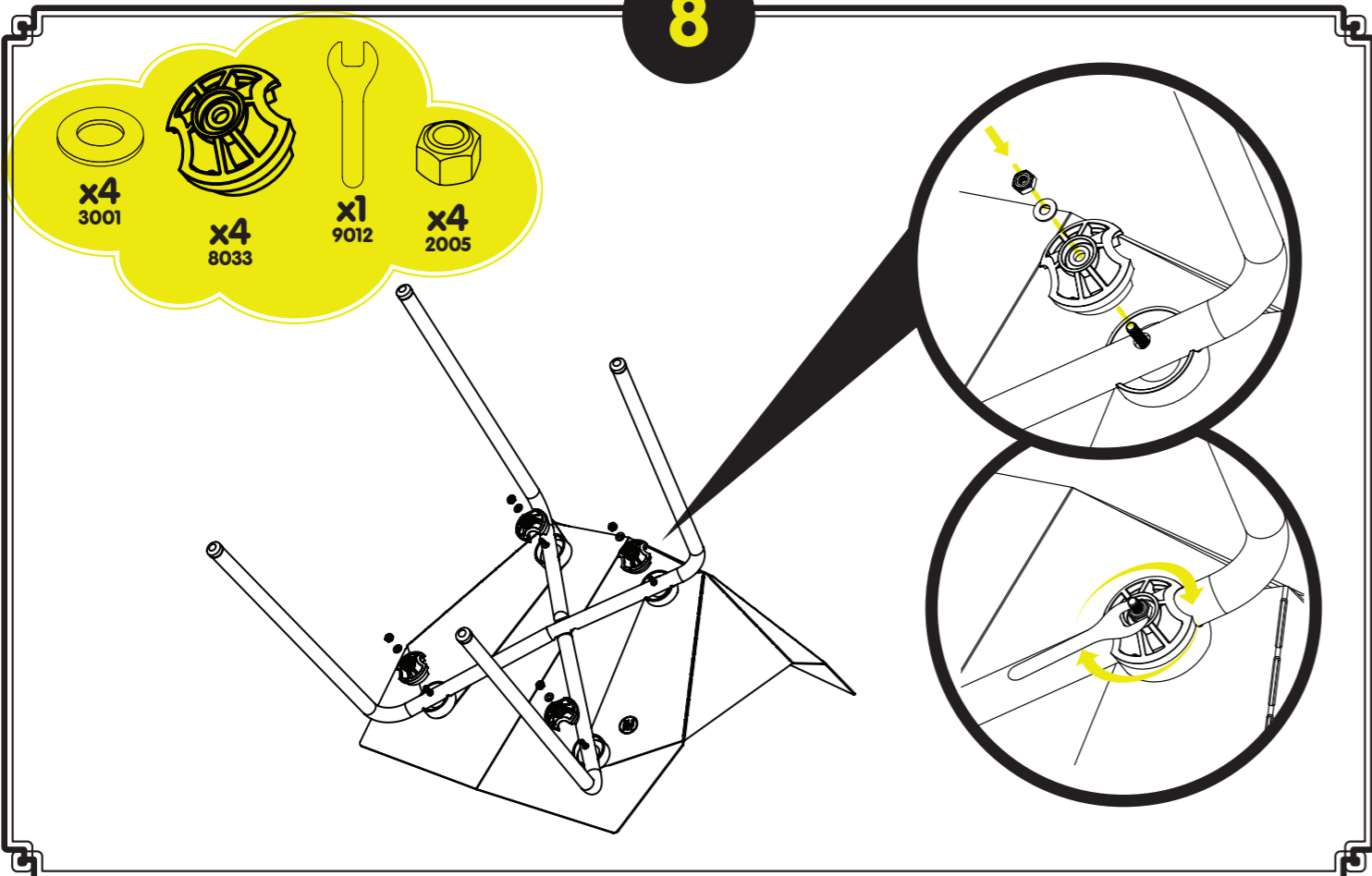

9

Tighten all fasteners; retighten periodically.



ADJUSTMENTS

TO REDUCE GAPPING AT (A):
TIGHTEN BOLT (A), THEN TIGHTEN NUT (B).

TO REDUCE GAPPING AT (B):
TIGHTEN NUT (B), TIGHTEN BOLT (A).